

Tankless Water Heater Accessories

Specification Sheet

Snorkel Kit

- Designed for all Noritz concentric vent (DVC) models
- Perfect for basement installations
- Standardized kits can accommodate for any lengths from 24" to 30"
- Length can be further adjusted for up to 45" with additional vent pieces
- Provides sufficient clearance of 12" to 18" from typical snow grade
- Kit comes included with fully adjustable snorkel case and complete concentric vent pieces

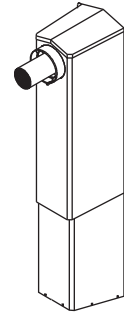

CVK-SNRK

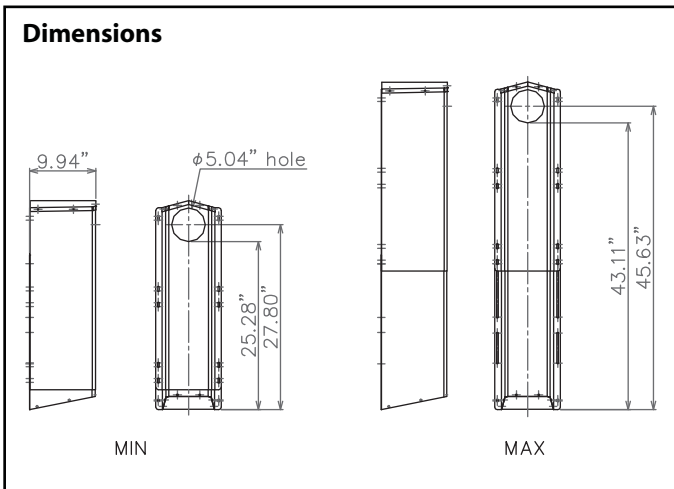

Compatible with All DVC Models

NR83-DVC
NR98-DVC

Installation Example

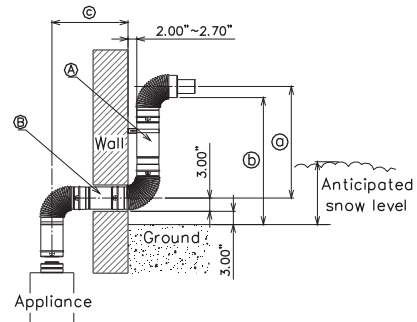

(A)	Vertical	
	(B)	(C)
CVP-11ADJ	23.90"~24.21"	27.40"~27.71"
CVP-16ADJ	23.91"~29.72"	27.41"~33.22"
CVP-16ADJ + CVP-4STR	28.09"~33.66"	31.59"~37.16"
CVP-11ADJ + CVP-12STR	33.01"~36.02"	36.51"~39.52"
CVP-16ADJ + CVP-12STR	35.70"~41.50"	39.20"~45.00"

(B)	Wall Thickness	
	(C)	(D)
CVP-11ADJ	16.45"~19.26"	
CVP-16ADJ	19.26"~24.97"	
CVP-16ADJ + CVP-4STR	23.20"~28.90"	
CVP-11ADJ + CVP-12STR	28.32"~31.27"	
CVP-16ADJ + CVP-12STR	31.07"~36.78"	

